

EN RIVAL STANDARD SNOW PLOW 60" INSTALLATION MANUAL

DE ANWEISUNGEN ZUM INSTALLIEREN EINER MONTAGEPLATTFORM ZUM INSTALLIEREN EINES SCHNEEPFLUGS

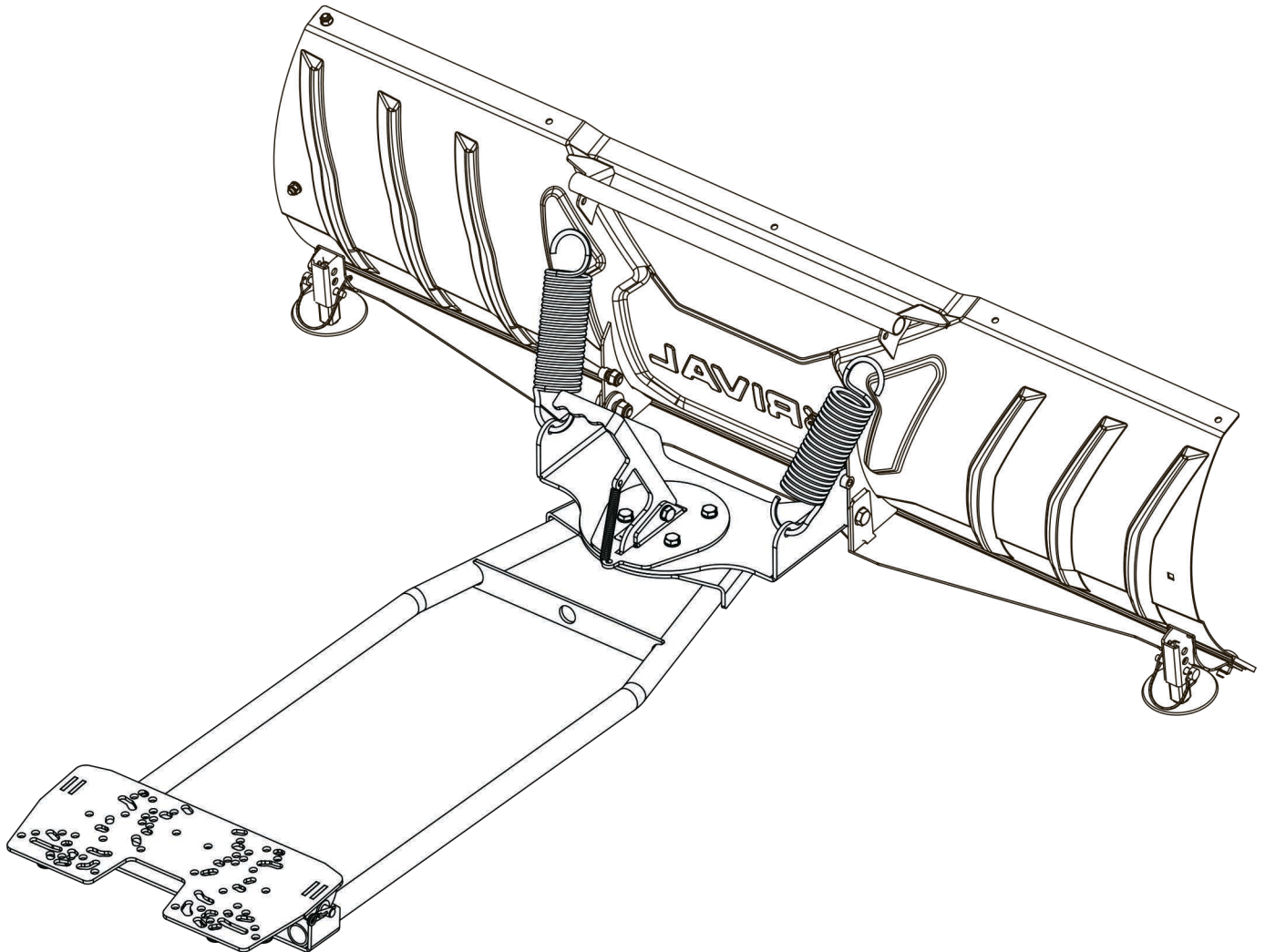

RIVAL STANDARD SNOW PLOW 60"

2444.0108.1

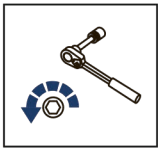

EN Regular fasteners
DE Originale montageile

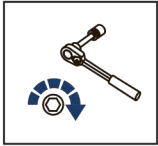

EN Regular fasteners
DE Originale montageile



EN Screw a several turns
DE Für wenigen Umdrehungen befestigen



EN Loosen bolts
DE Bolzen lockern

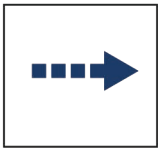



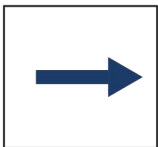







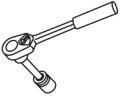



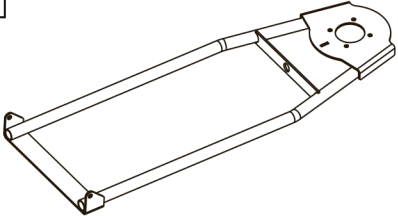
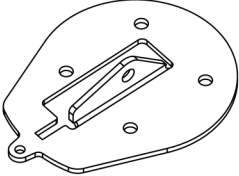
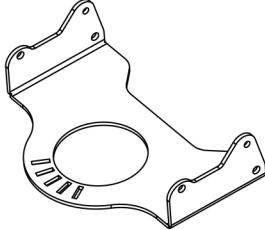
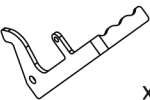
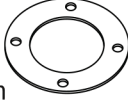
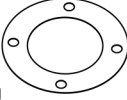
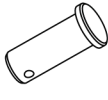
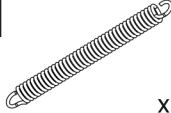





EN Movement Arrow
DE Bewegungsrichtung

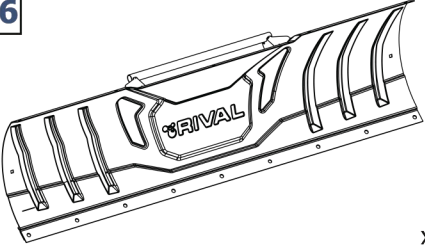
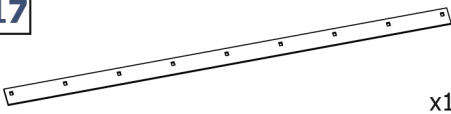
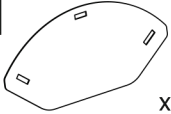
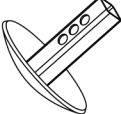
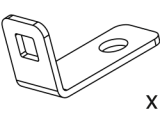
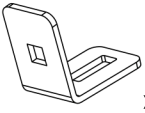
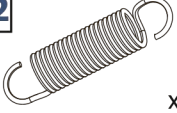
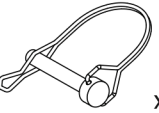

EN Location/Position Arrow
DE Anordnung/Positionsrichtung

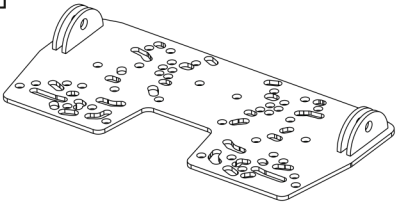
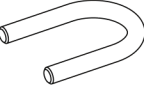
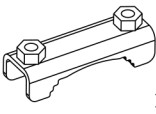
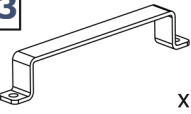
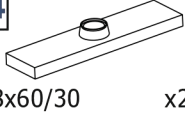
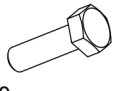
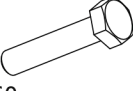

EN Screw Arrow
DE Drehungsrichtung

 EN Ratchet DE Ratsche		 S - 13; S - 17; S - 19		 EN Slotted Screwdriver DE Schlitzschraubendreher		 HEX S - 6; S - 8			
1  x1		2  x1		3  x1					
4  x1	5  6mm x1	6  1mm x1	7  x2	8  x1	9  x2				
10  M10x35 x4	11  M12x40 x3	12  ø10 x19	13  ø12 x8	14  M10 x15	15  M12 x3				
16  x1	17  x1		18  x1	19  x2					
		20  x2	21  x1	22  x2	23  x2				
24  M8x20 x1	25  M8x20 x4	26  M10x20 x2	27  M10x30 x9	28  ø8 x8	29  ø12 x4				
30  x1	31  x4	32  x4	33  x2	34  M8x60/30 x2					
		35  M8x30 x4	36  M8x60 x8	37  ø8 x10	38  M8 x13				

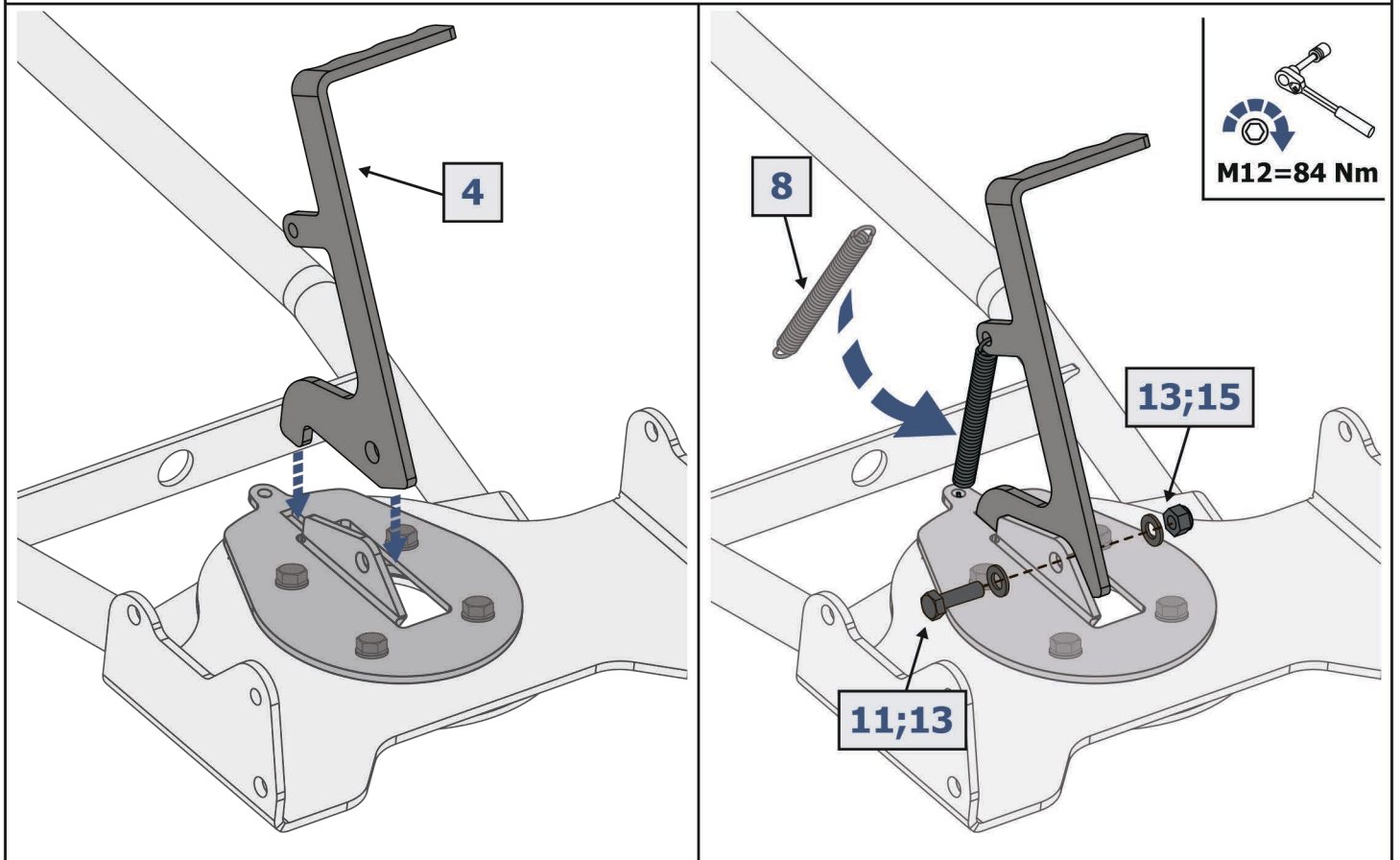
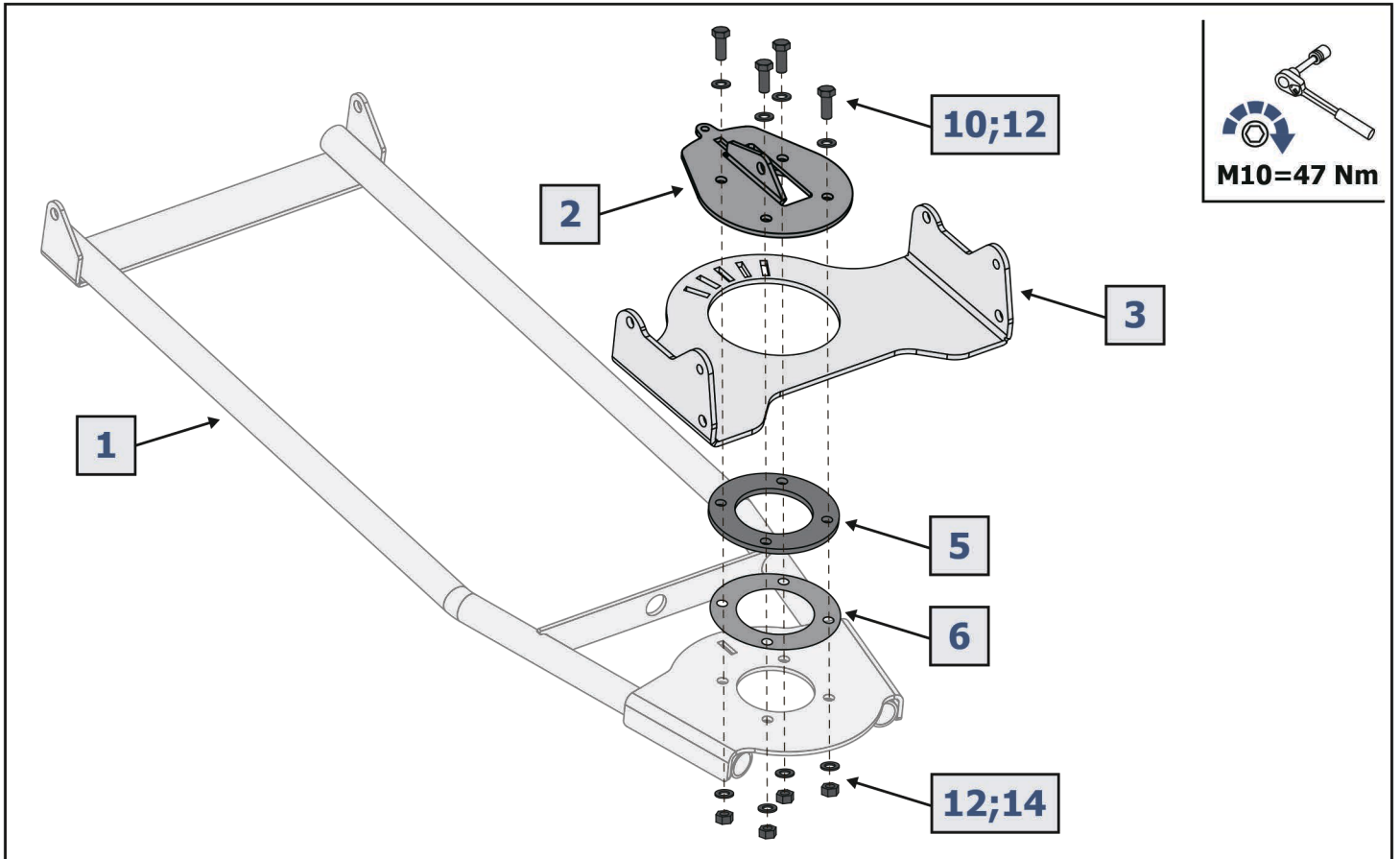

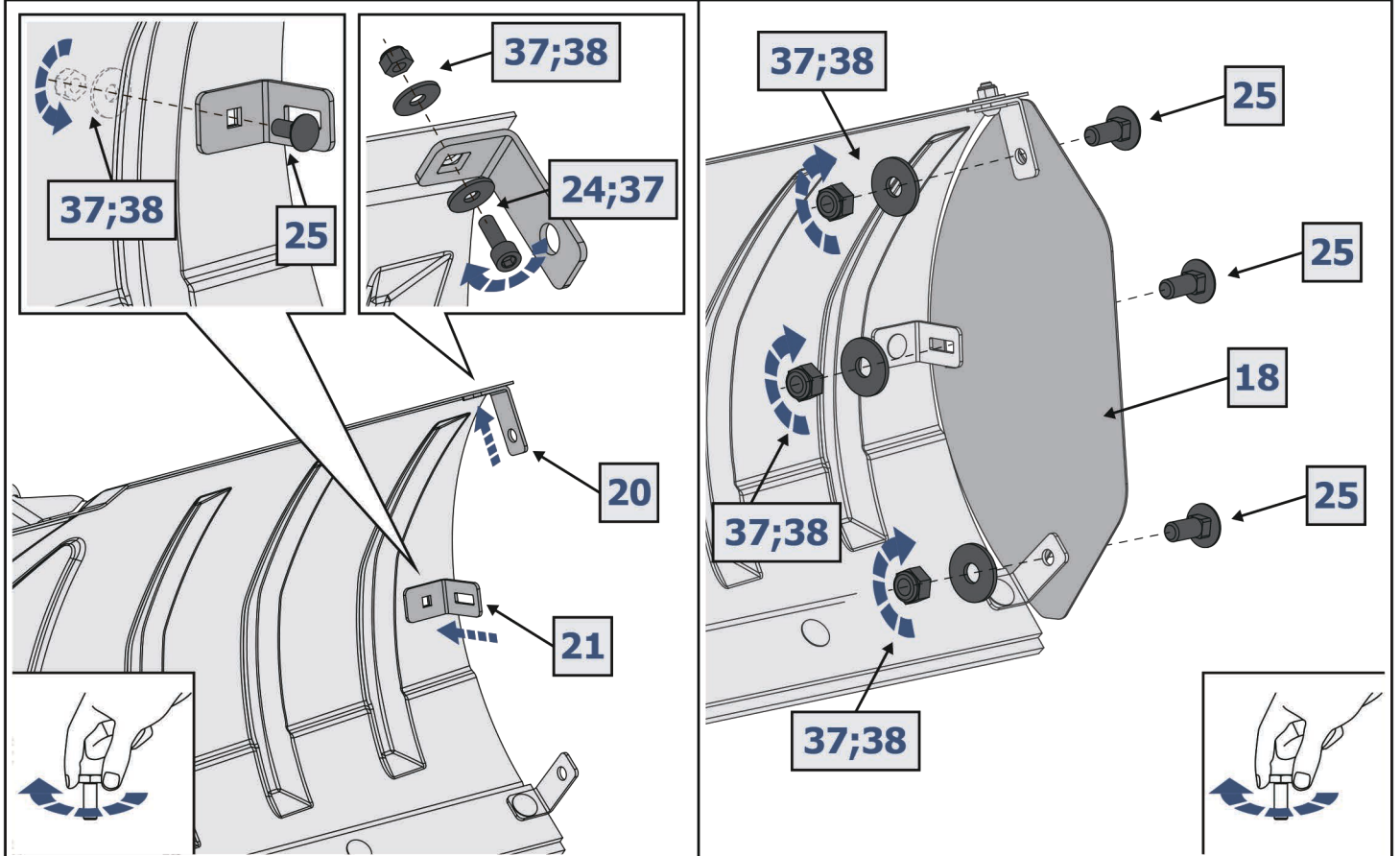
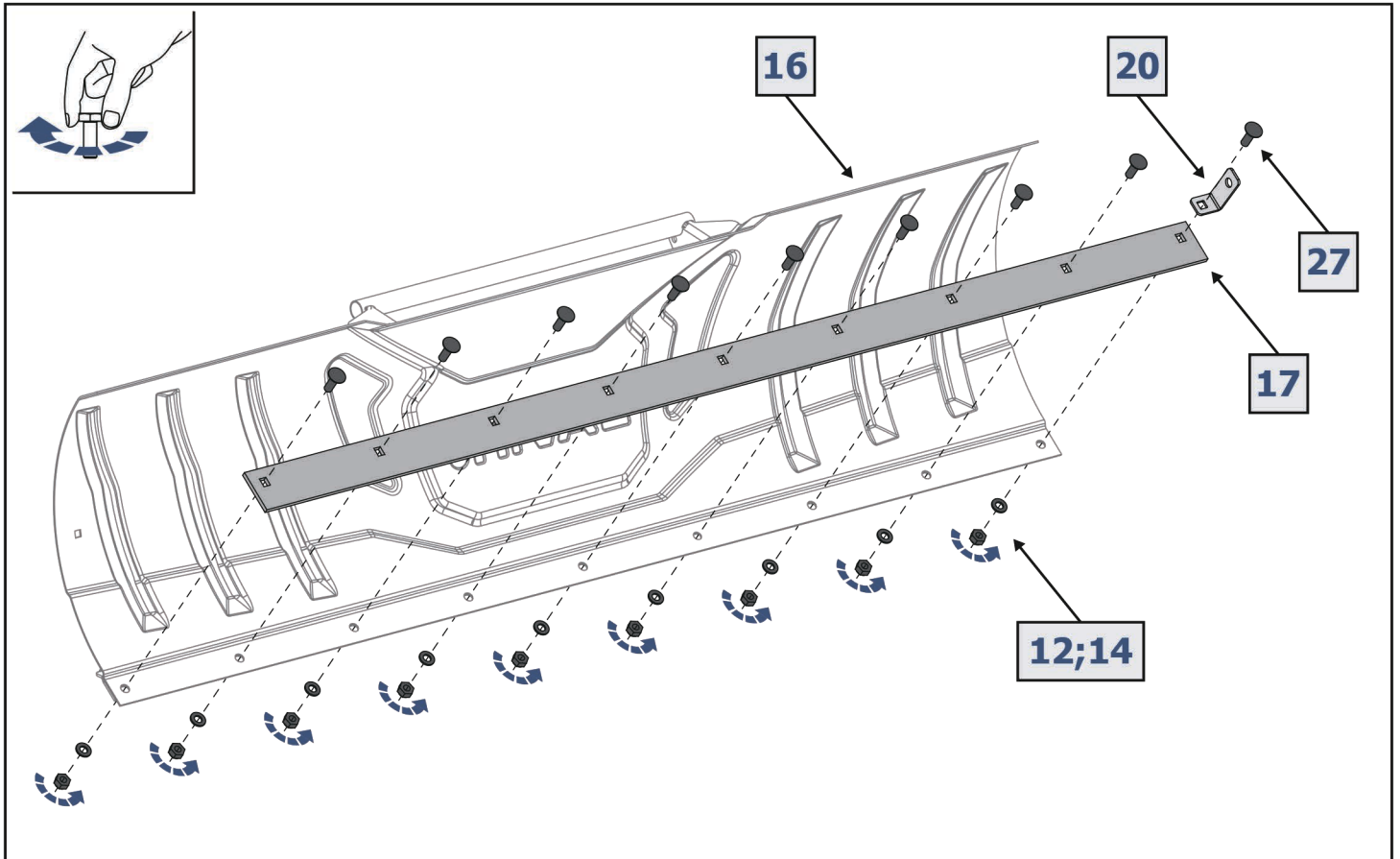

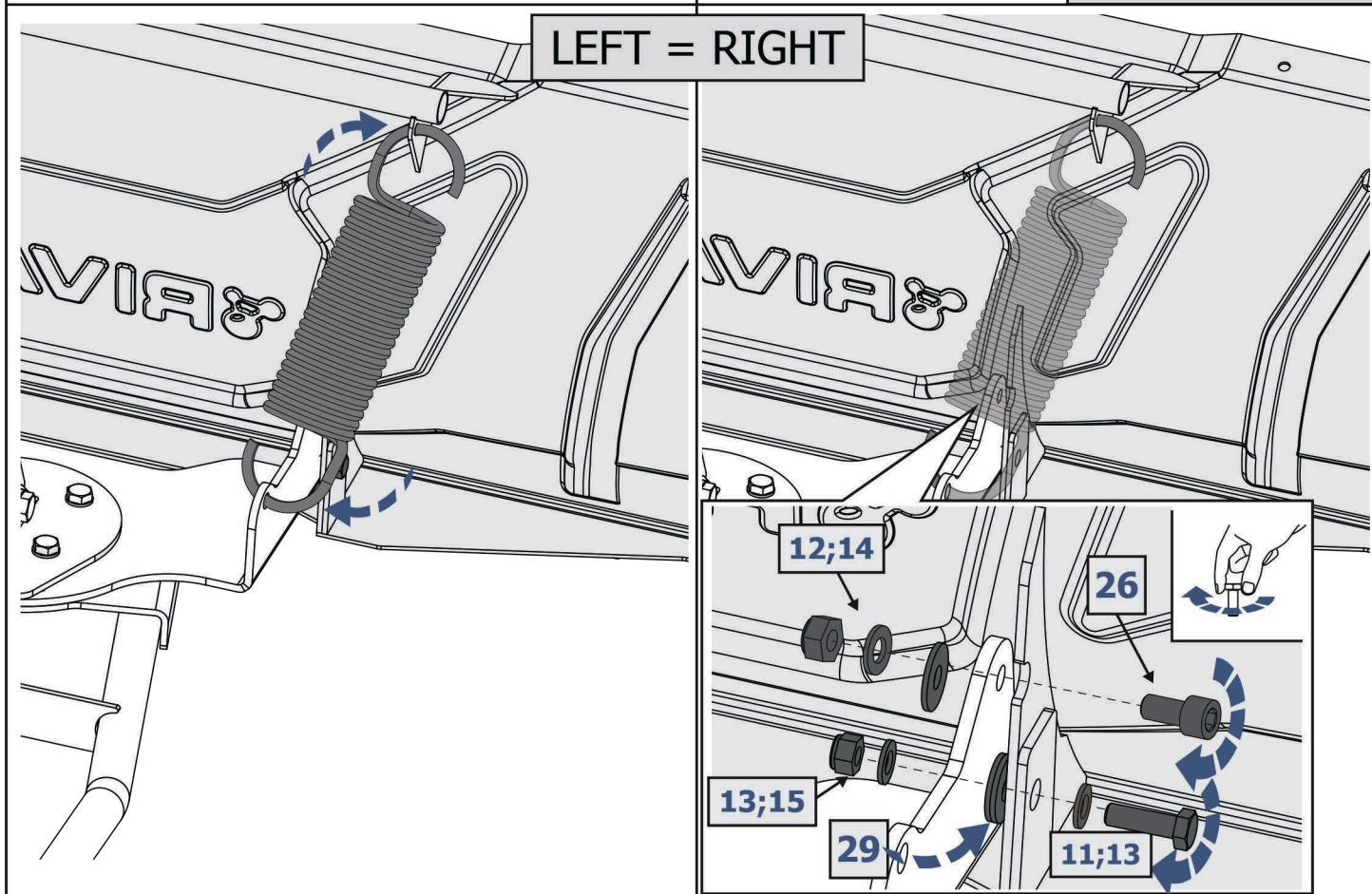
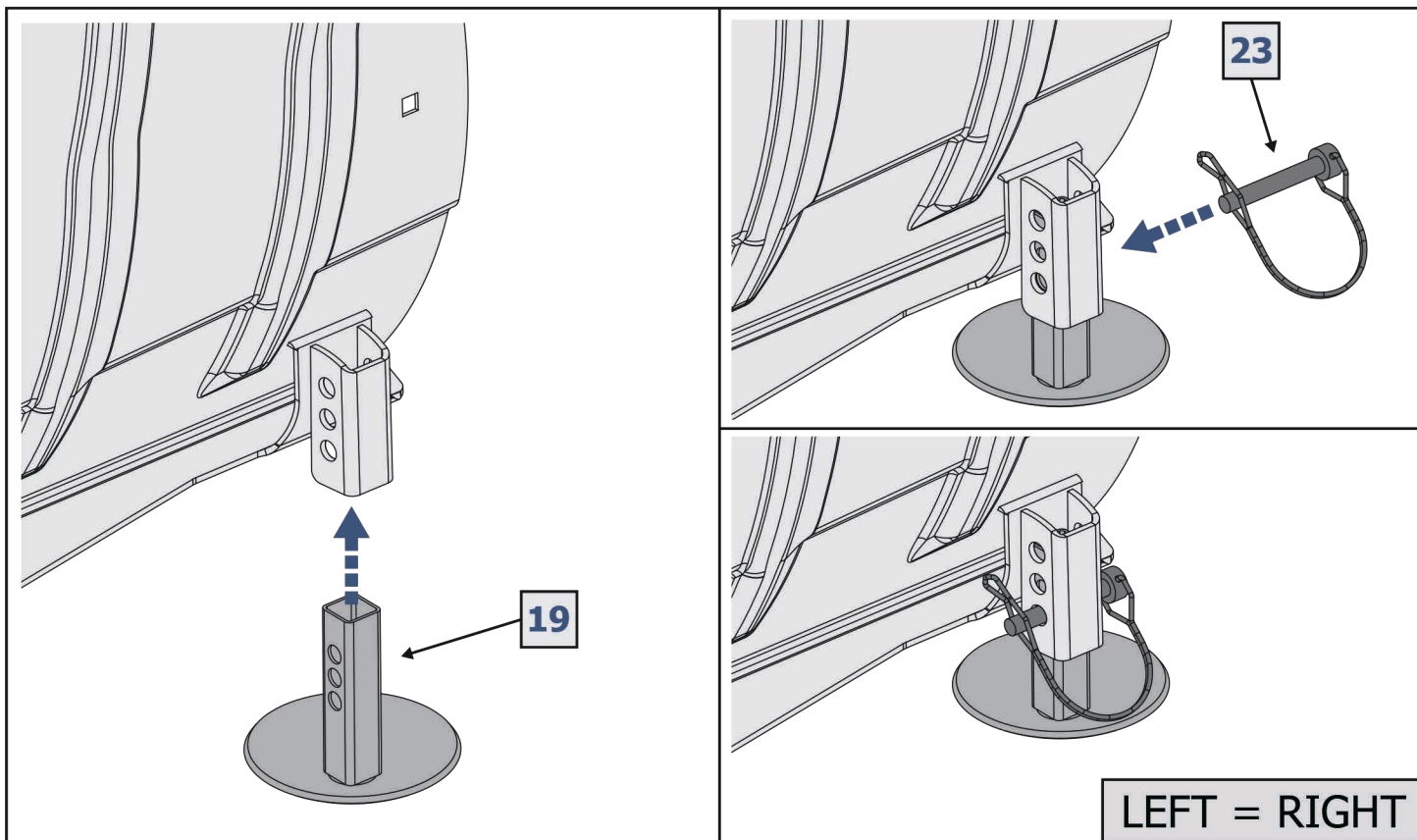

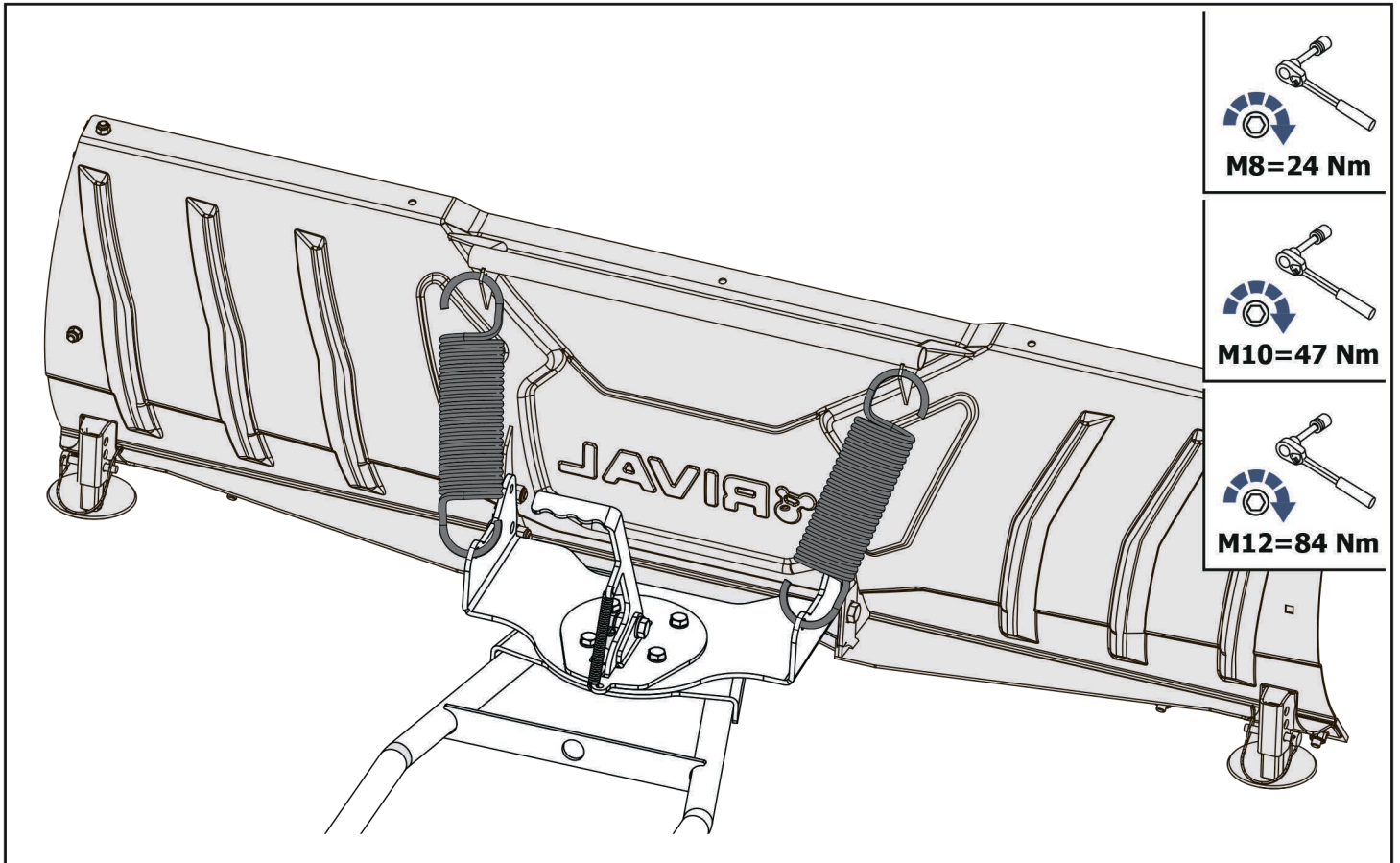

Can-Am Outlander G2, G2L, Renegade G2S

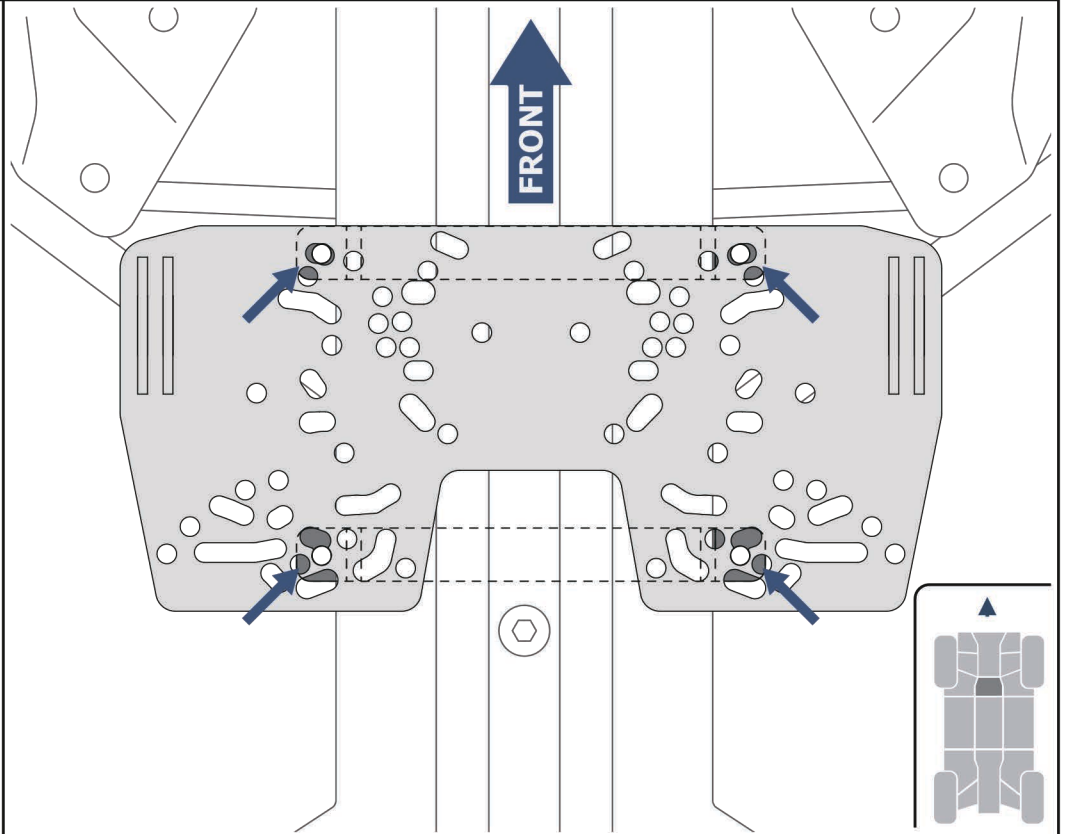
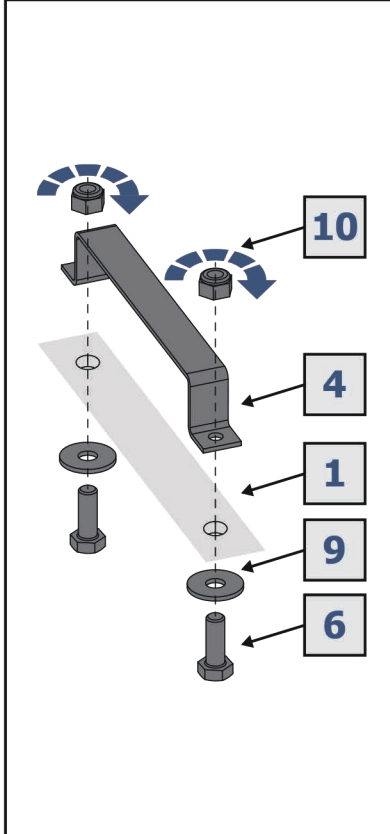

CFMOTO: CForce 400, 450, 520

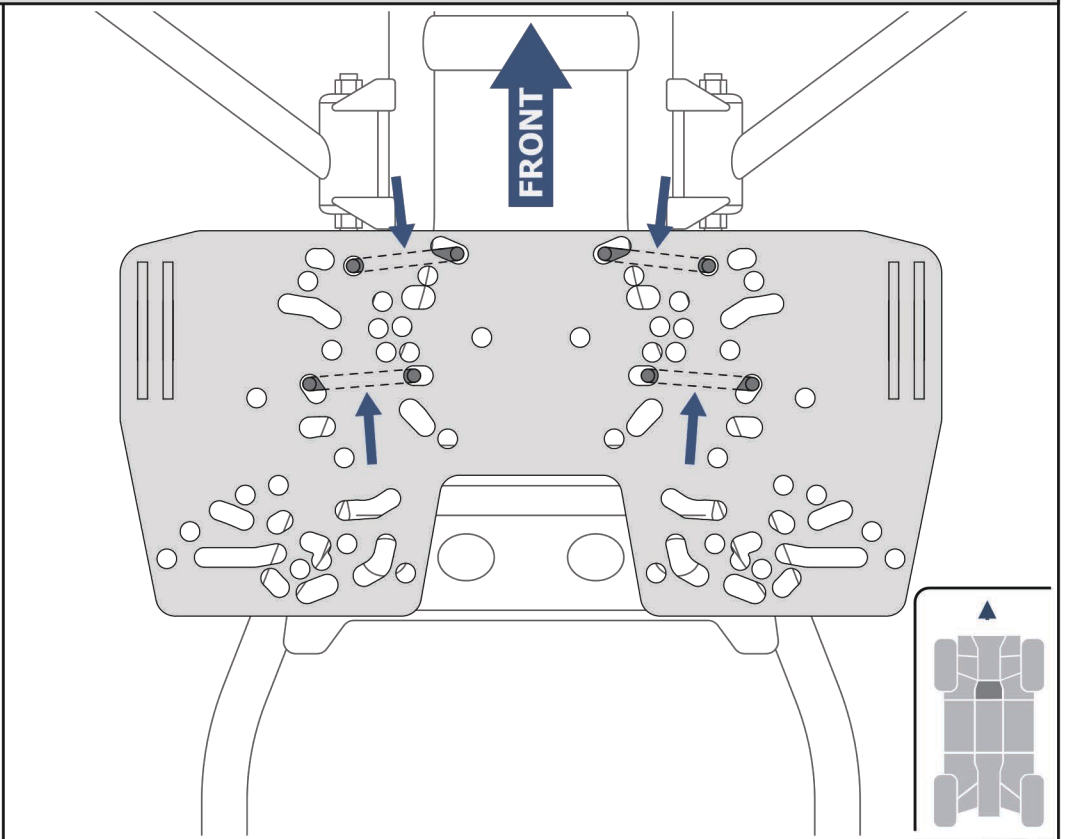
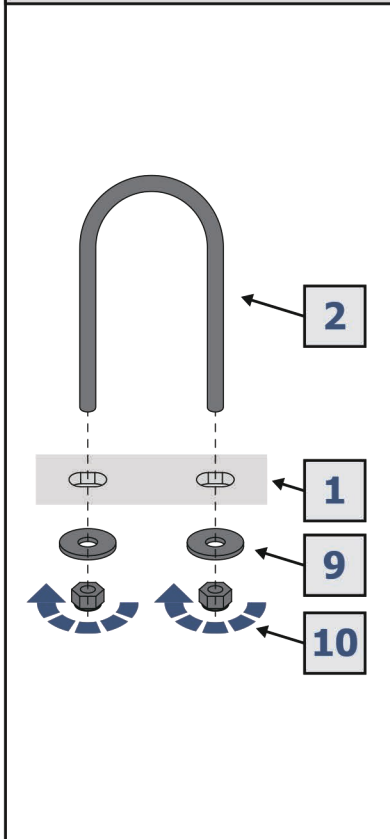

CFMOTO CForce 550

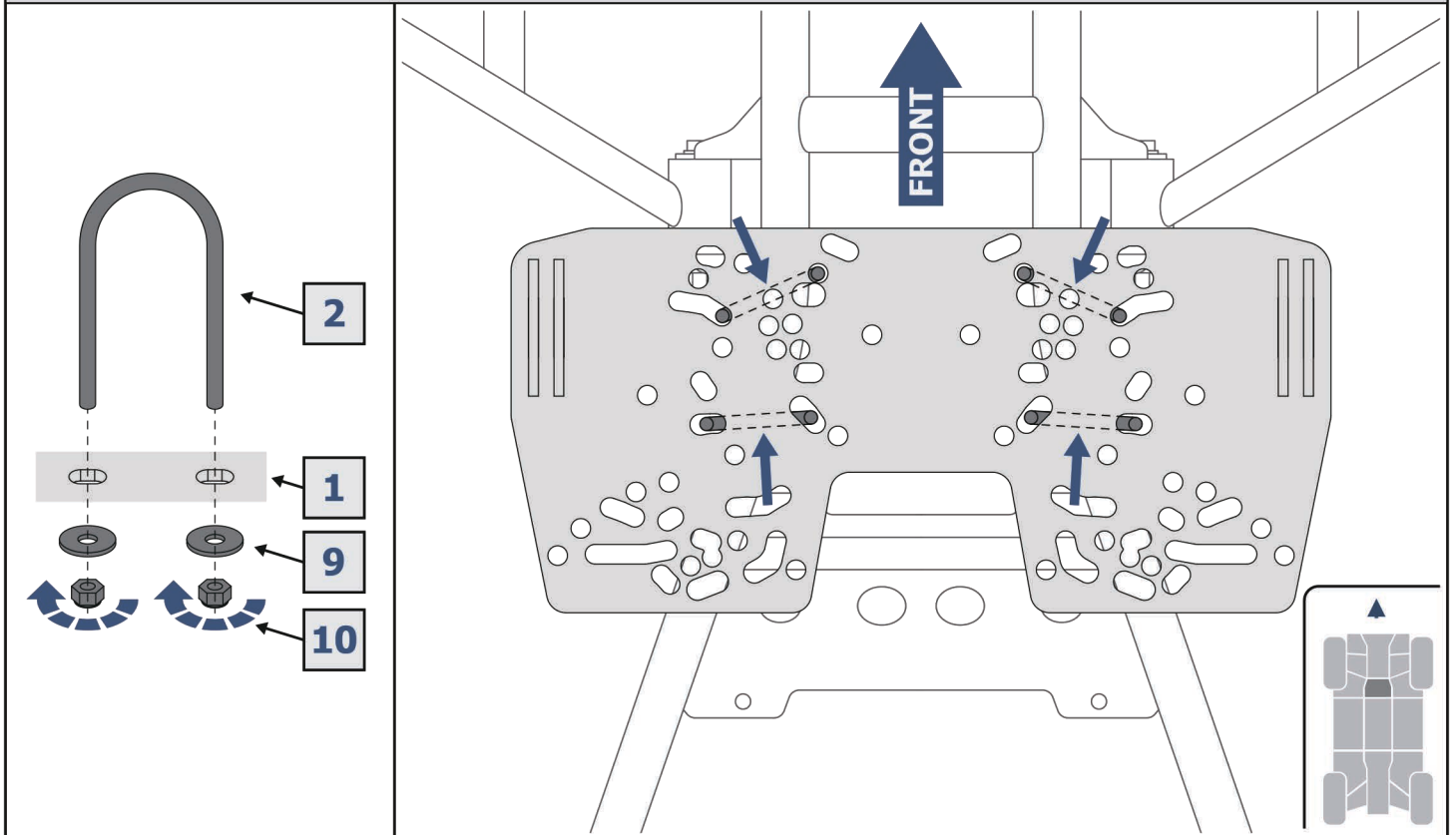

CFMOTO CForce 500, 600

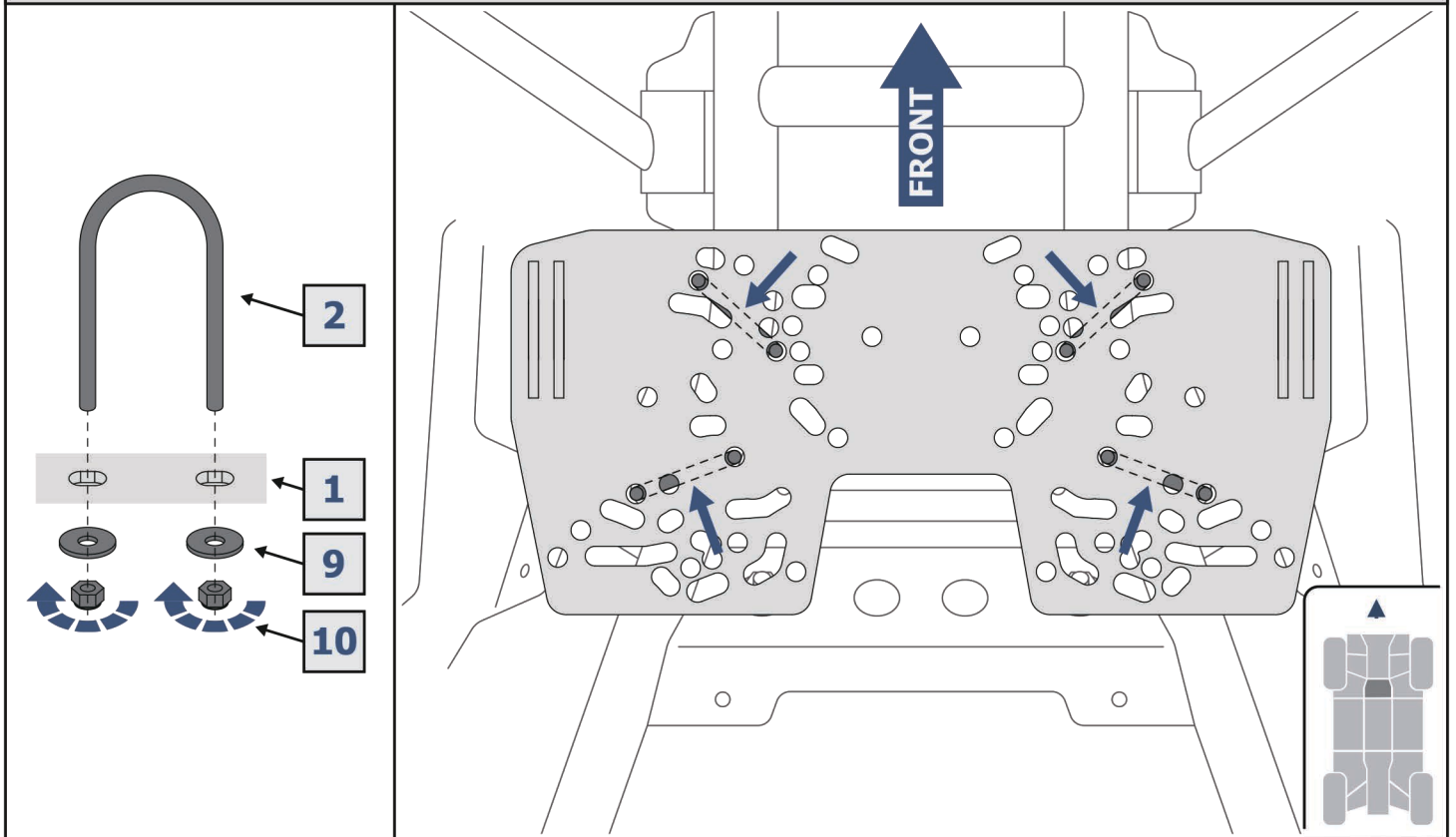

CFMOTO CForce 625

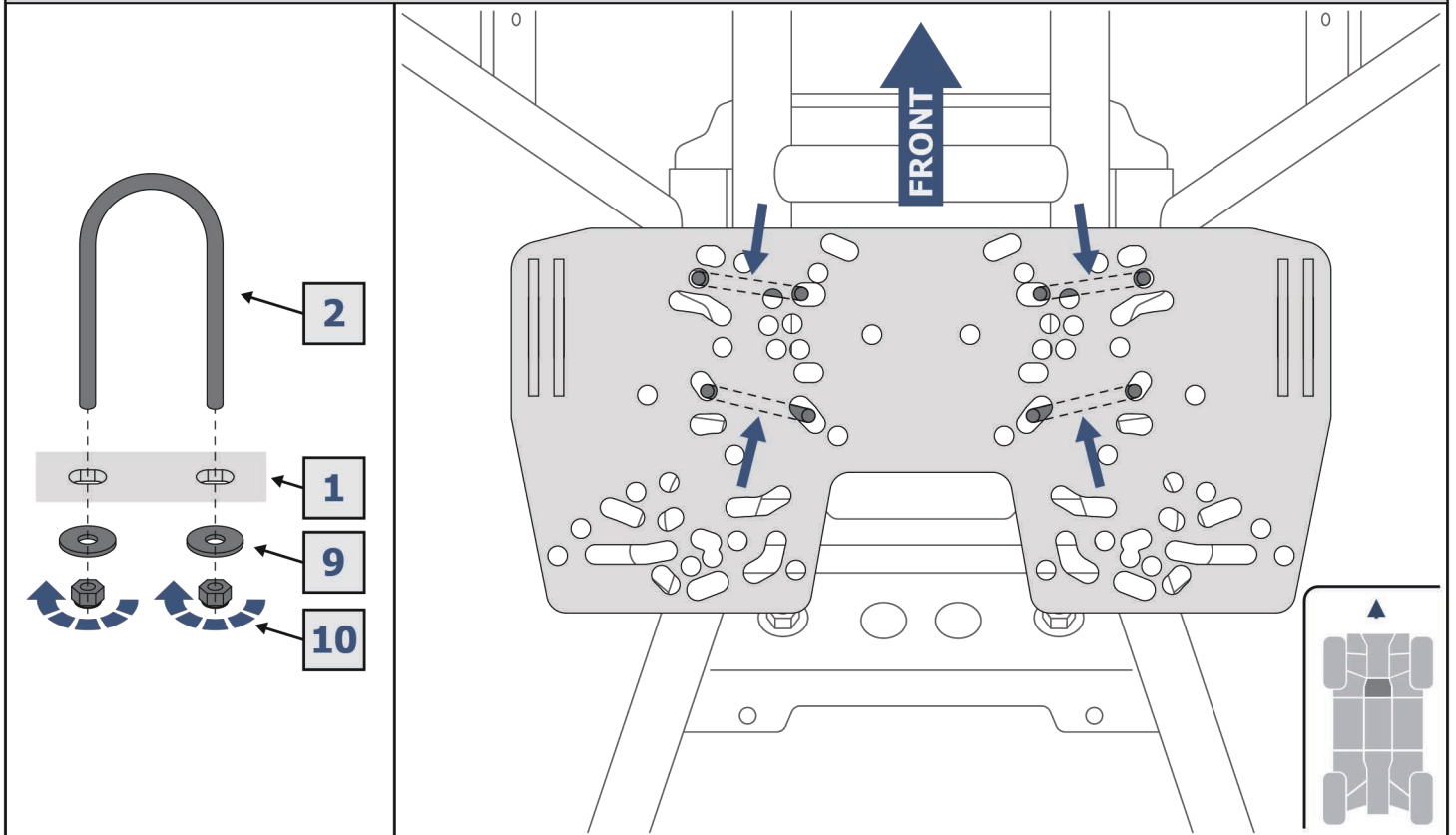

CFMOTO CForce 800, 820

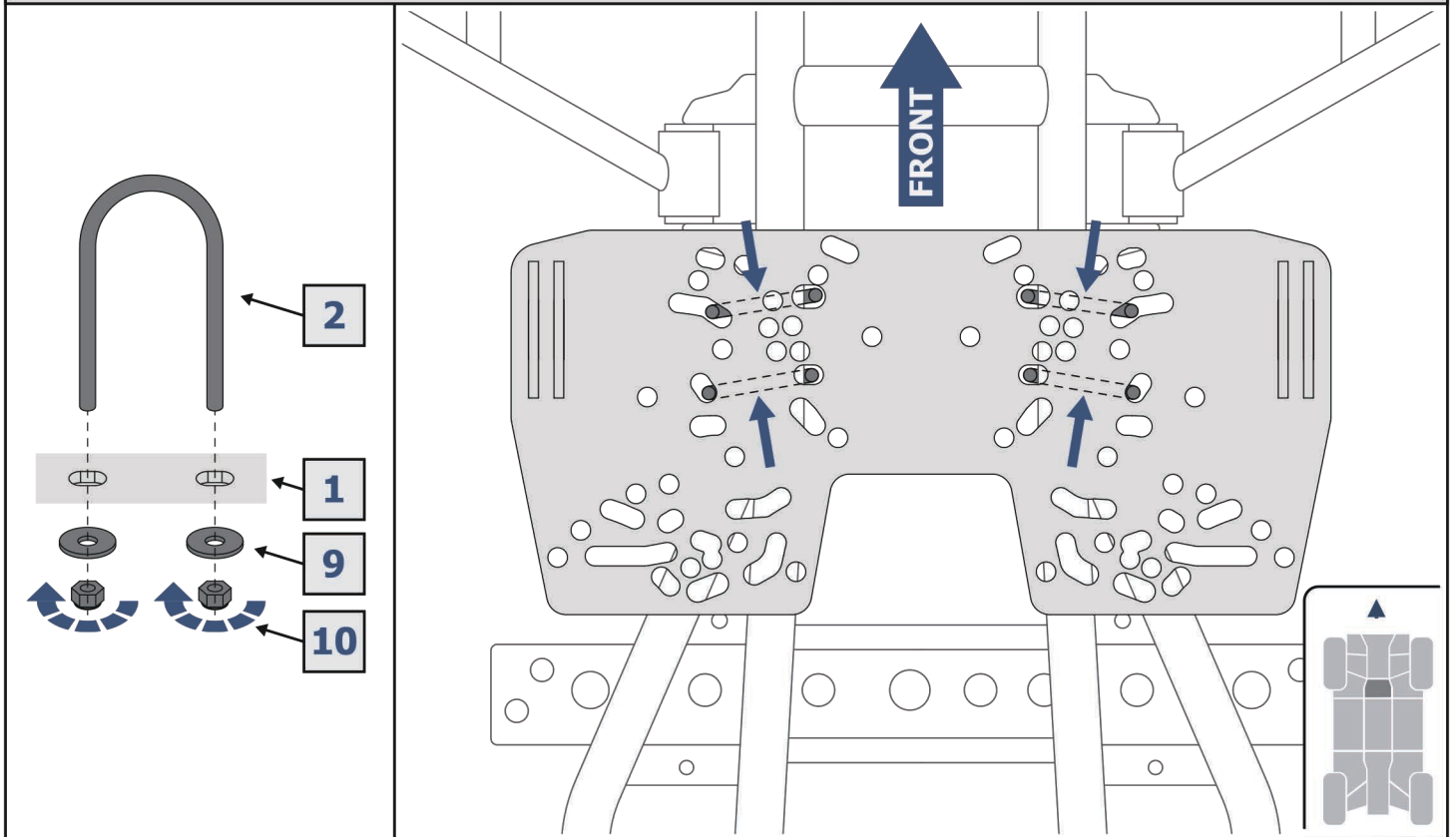

CFMOTO CForce 850, 1000

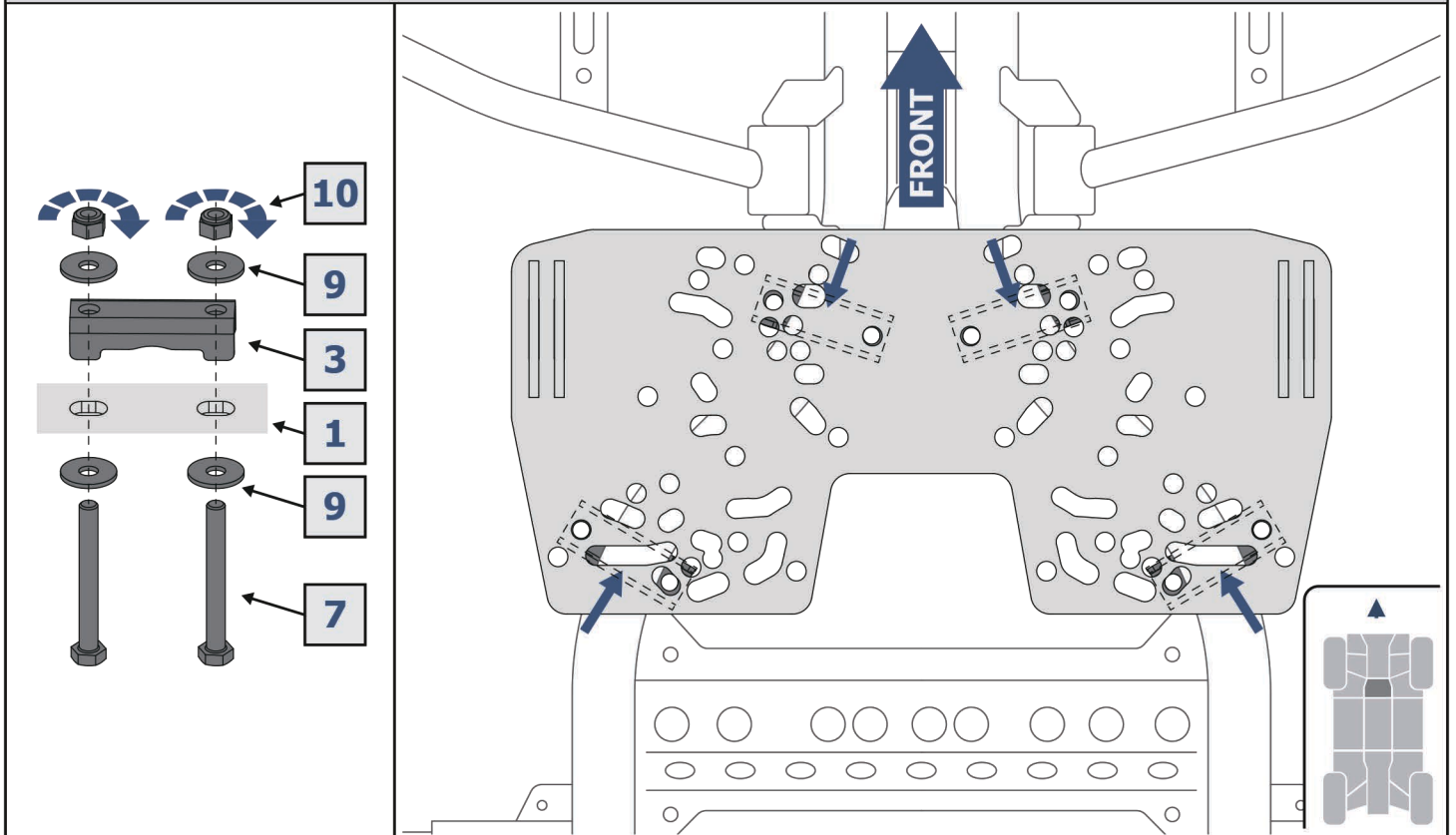

Honda TRX 420, 500, 520

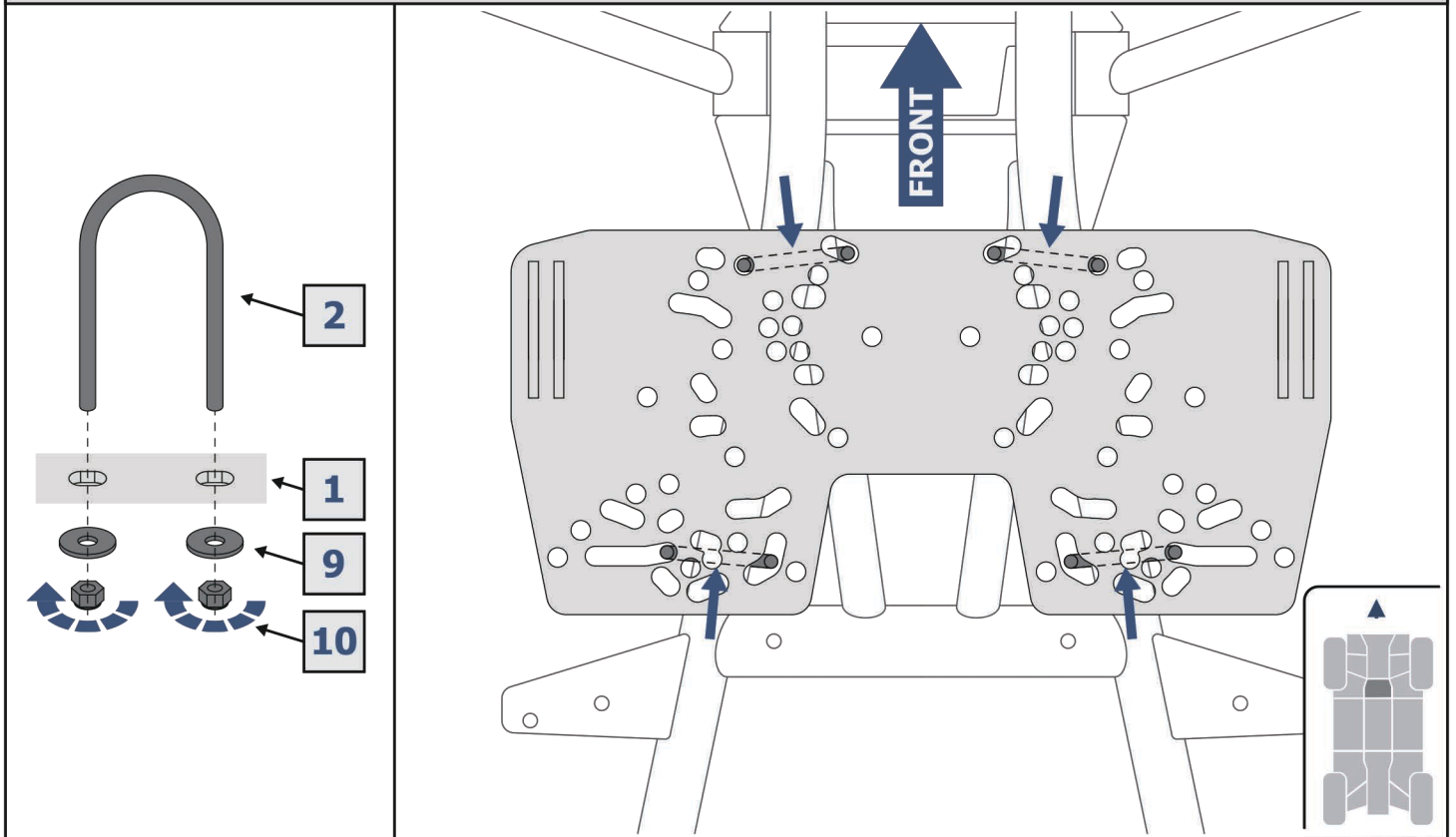

Honda TRX 680

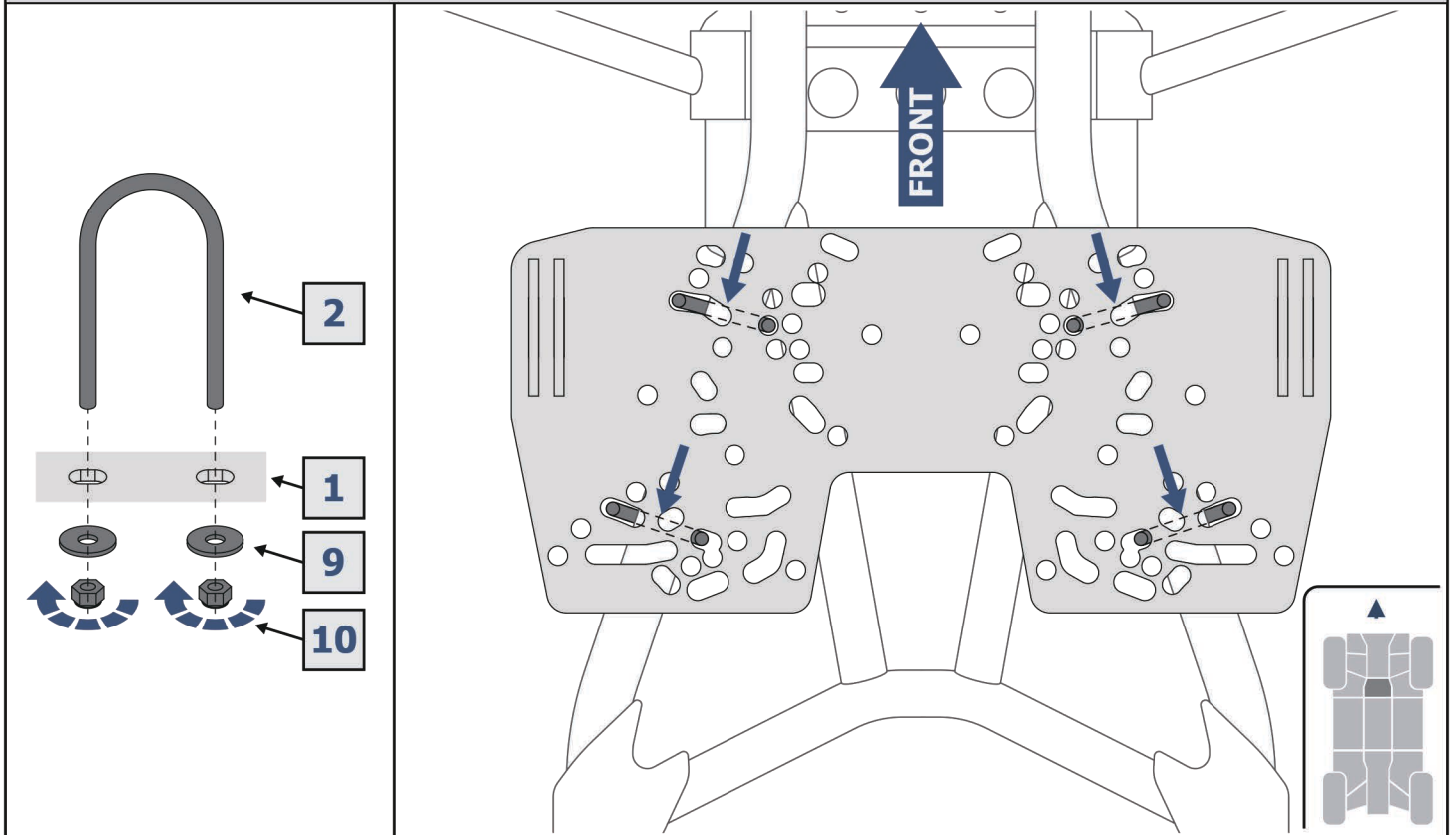

Kawasaki KVF 750

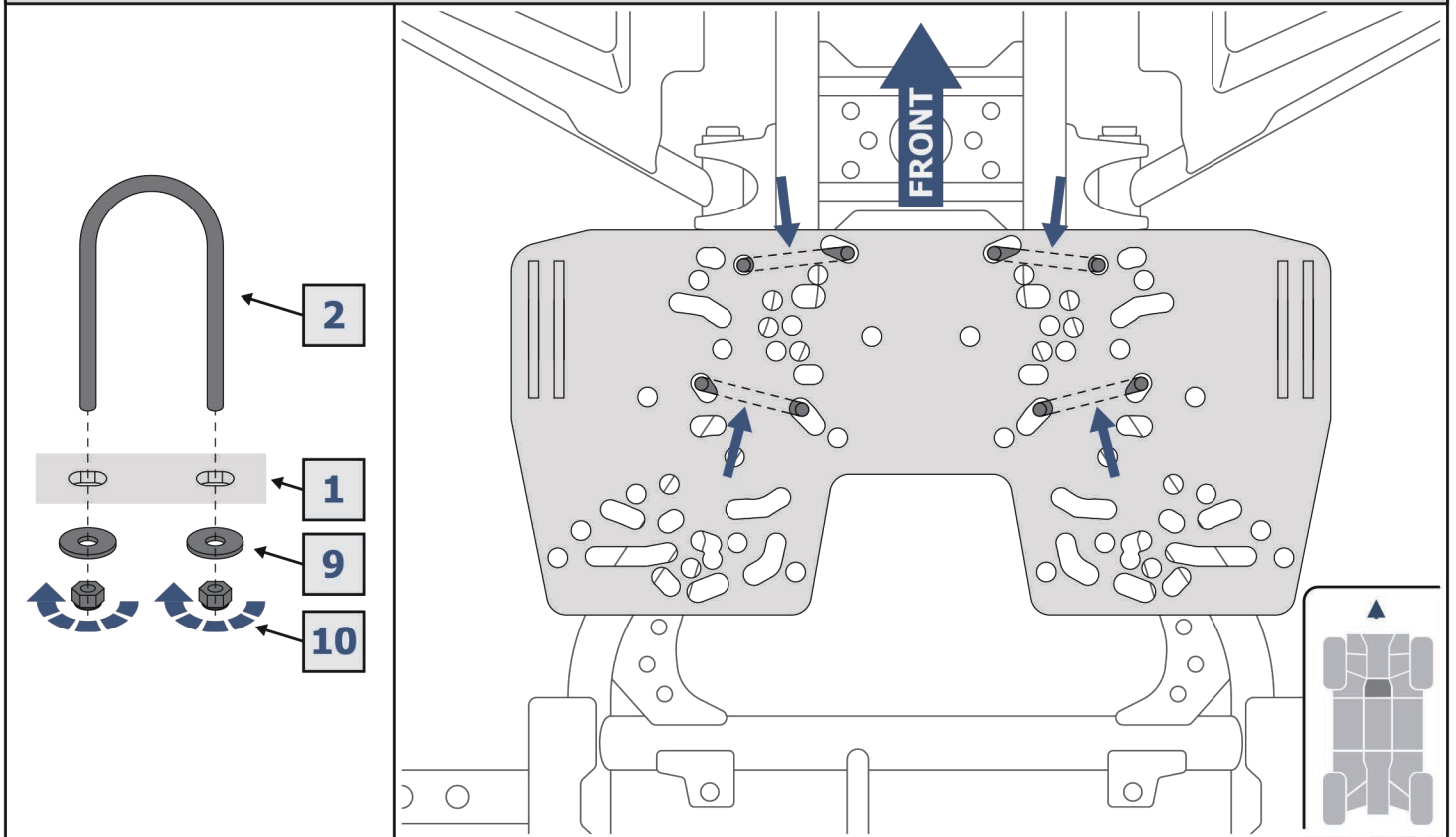

Kymco MXU 700 (2019-)

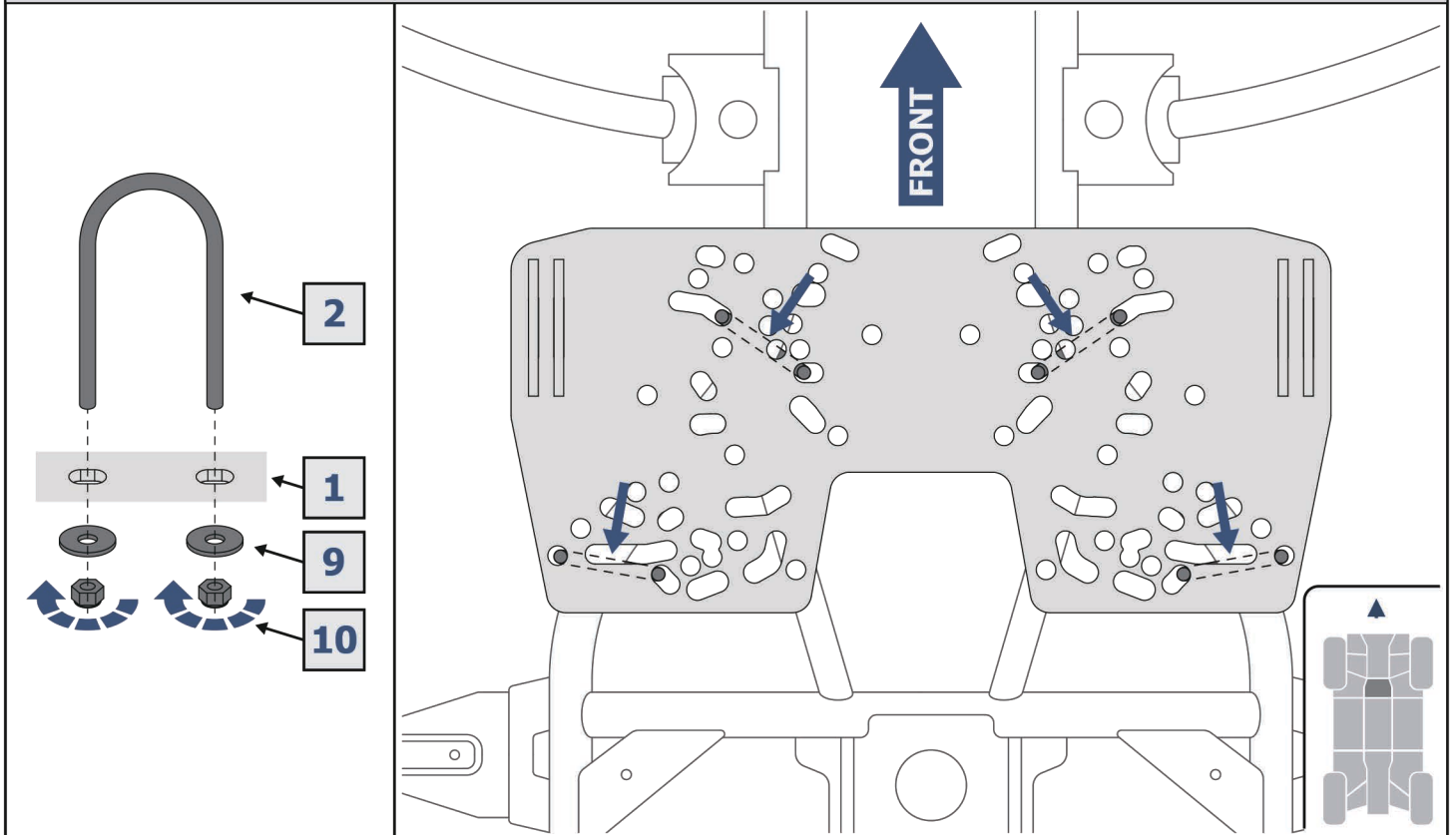

Polaris Touring Sportsman 850

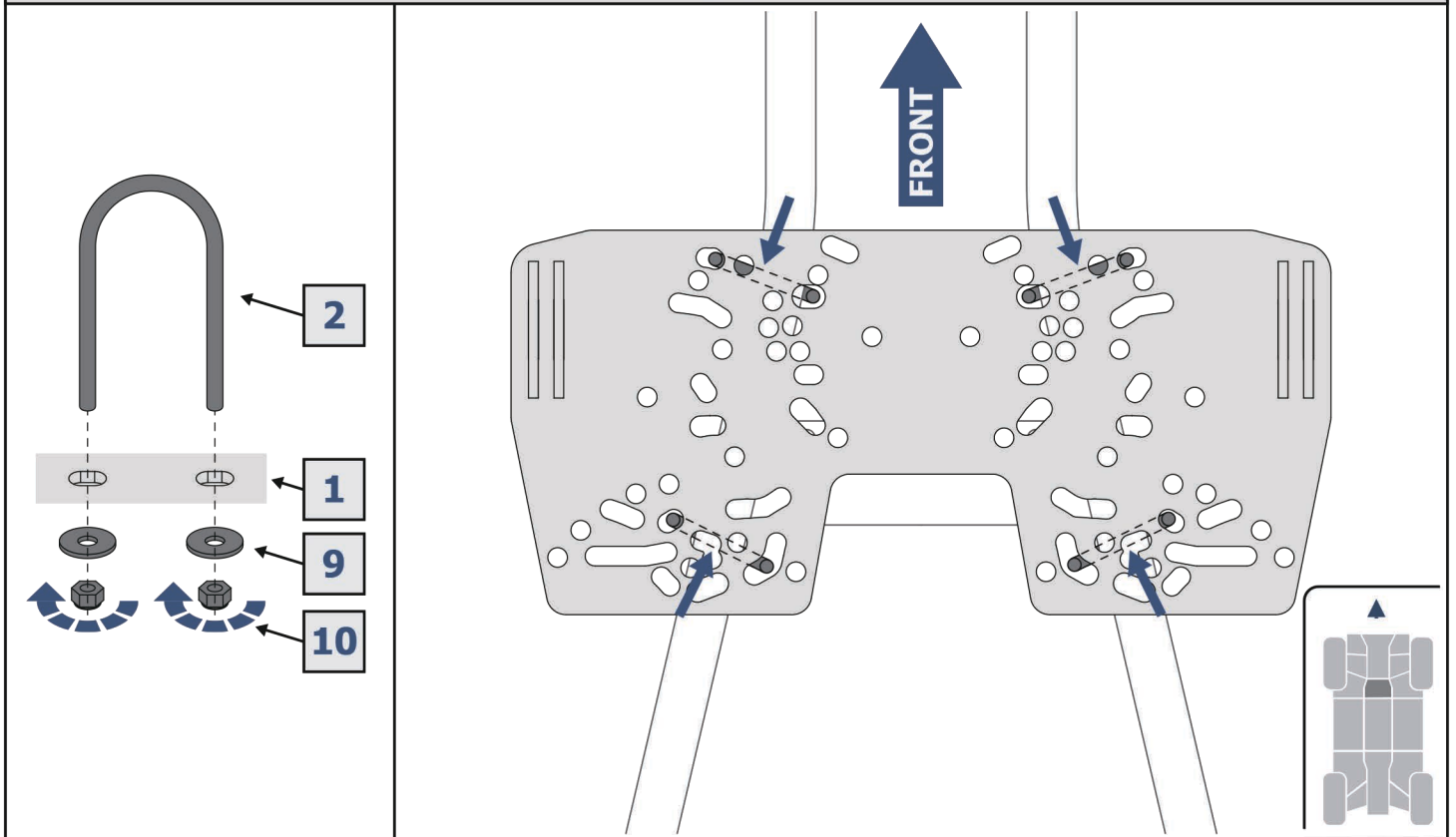

Polaris Scrambler 1000

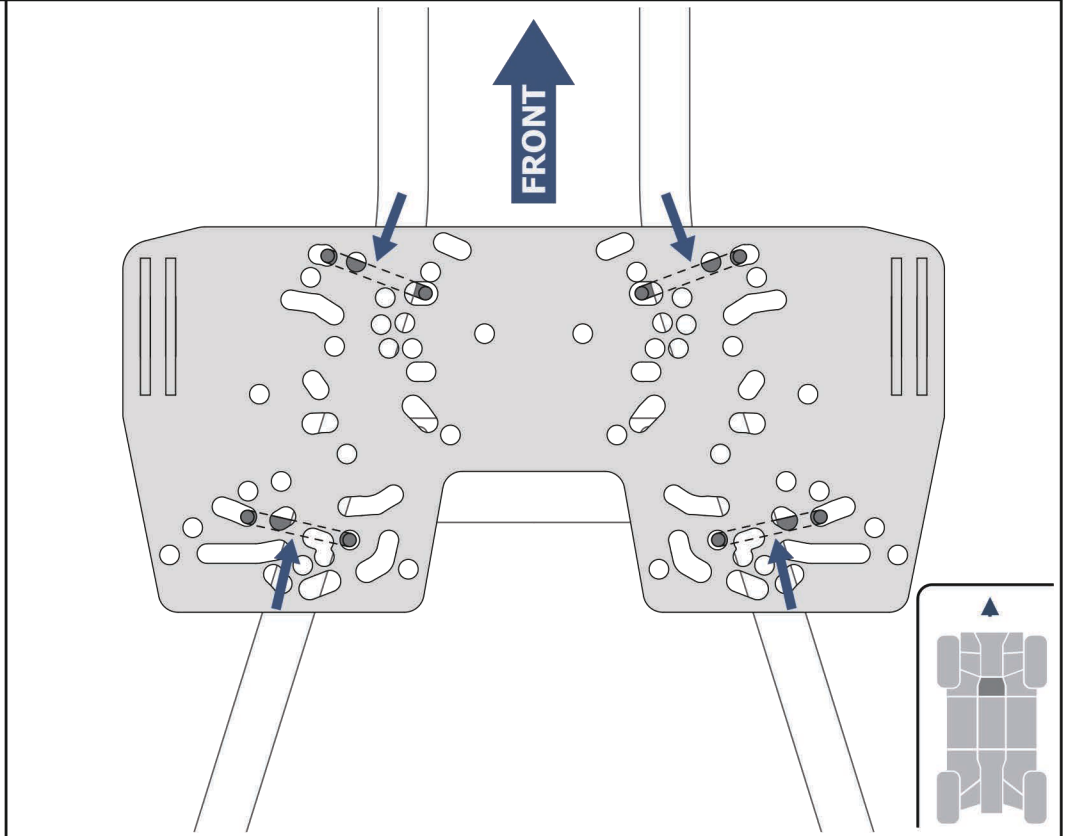
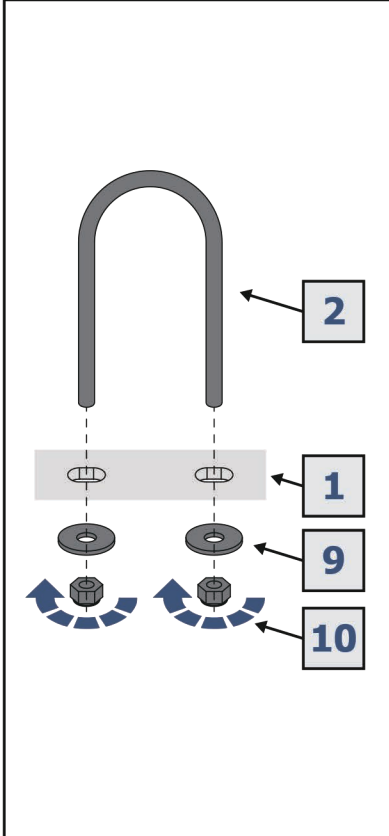

Segway Snarler AT6

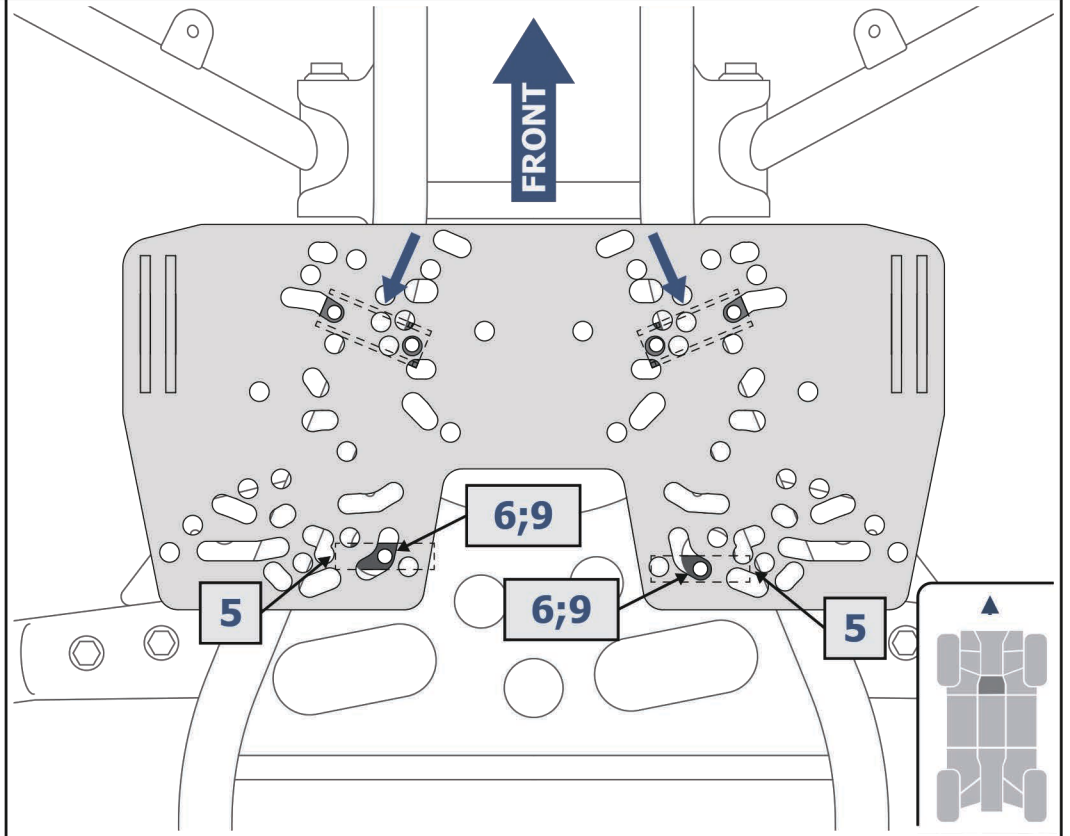
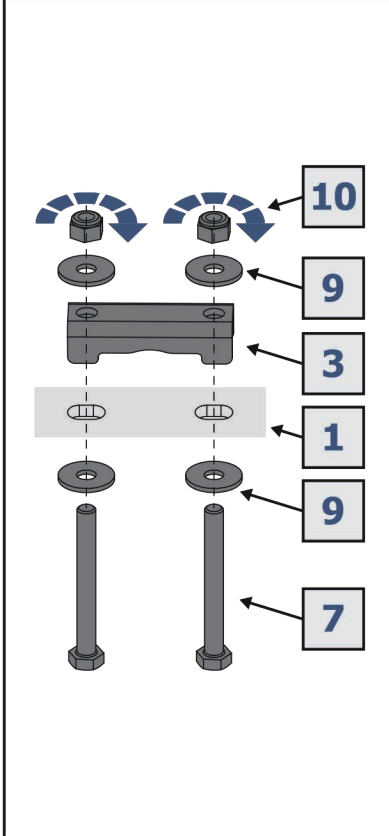

Suzuki Kingquad 400, 750

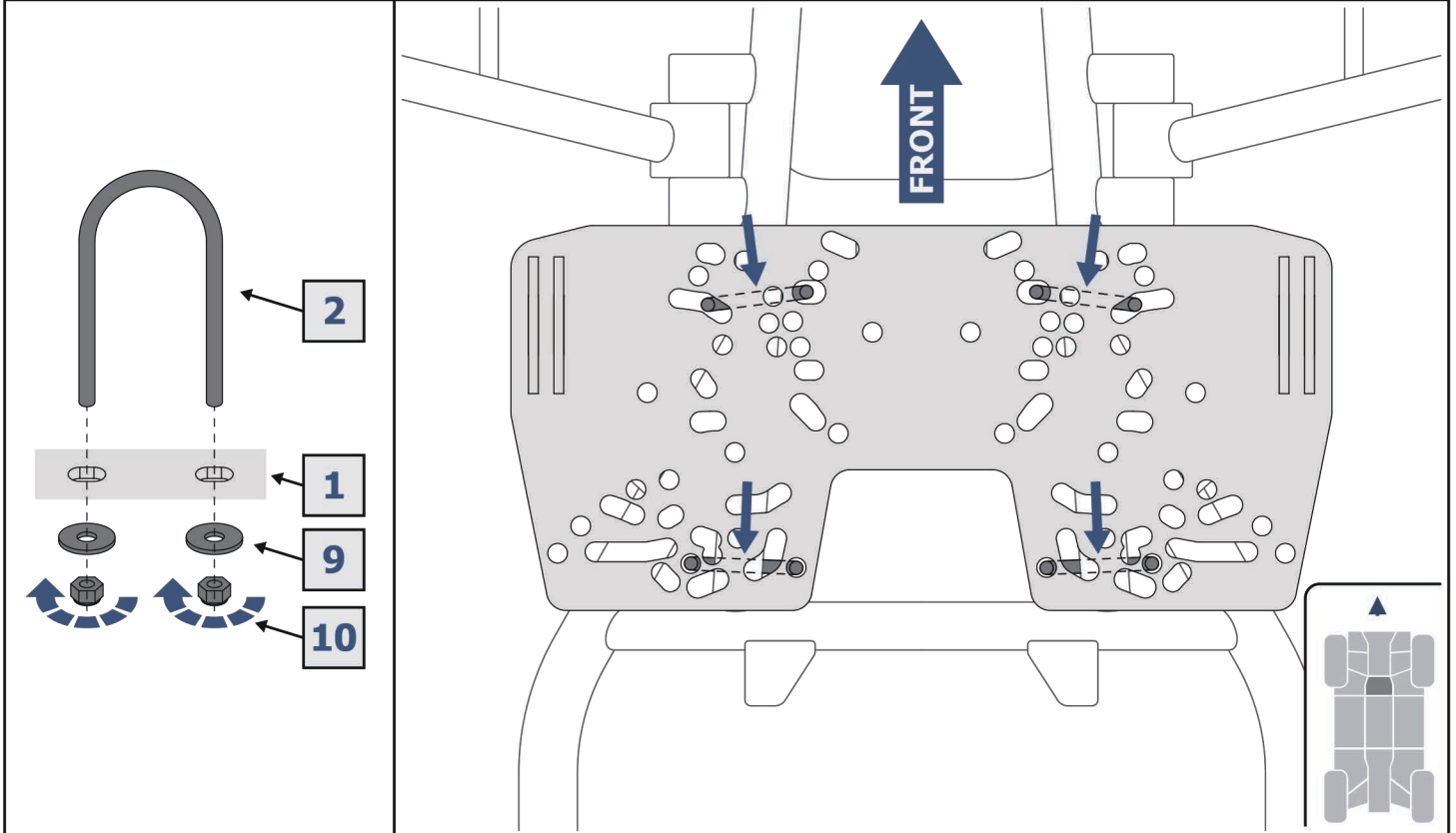

Yamaha: Grizzly 350, 450

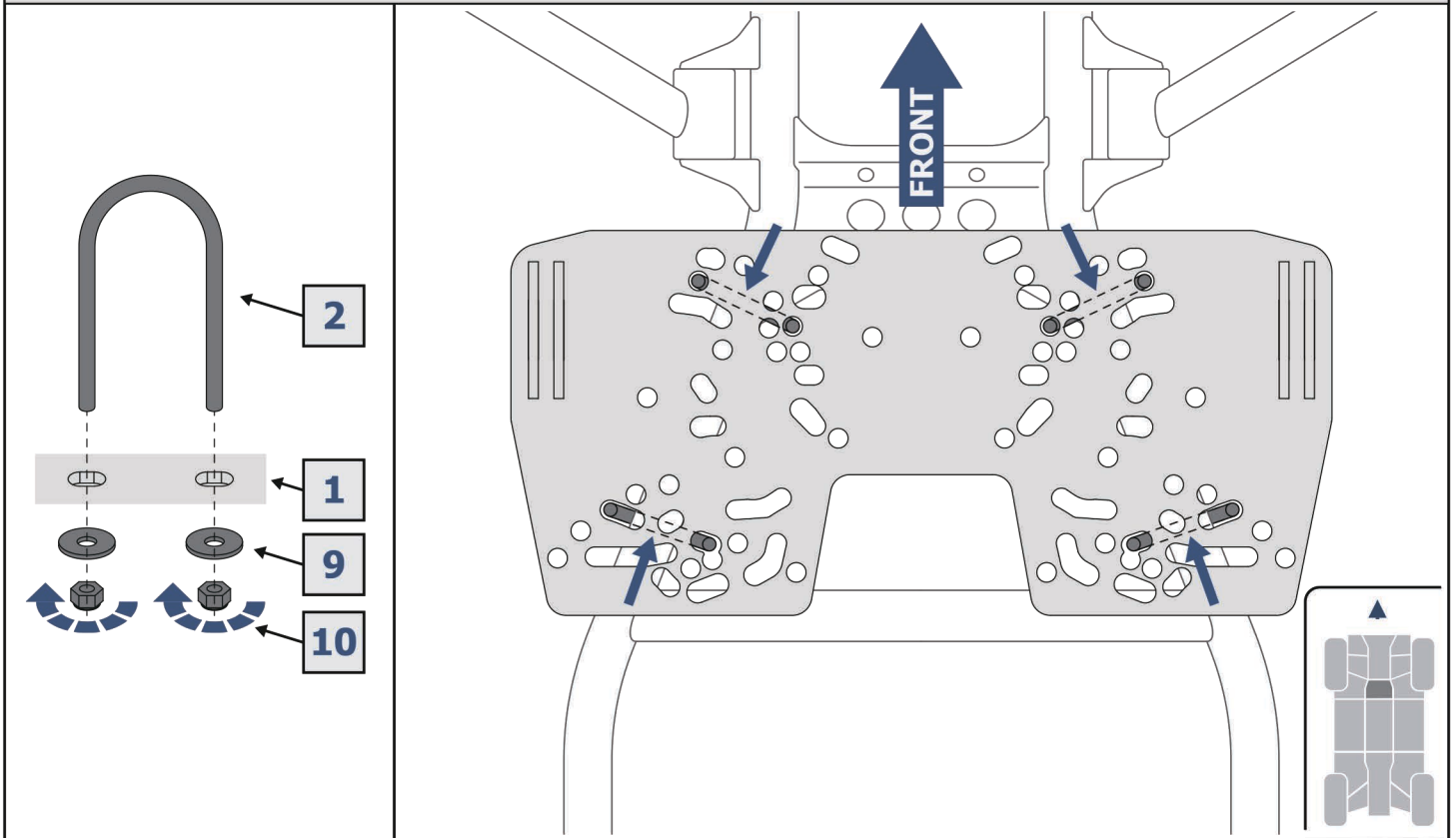

Yamaha: Grizzly 550, 700

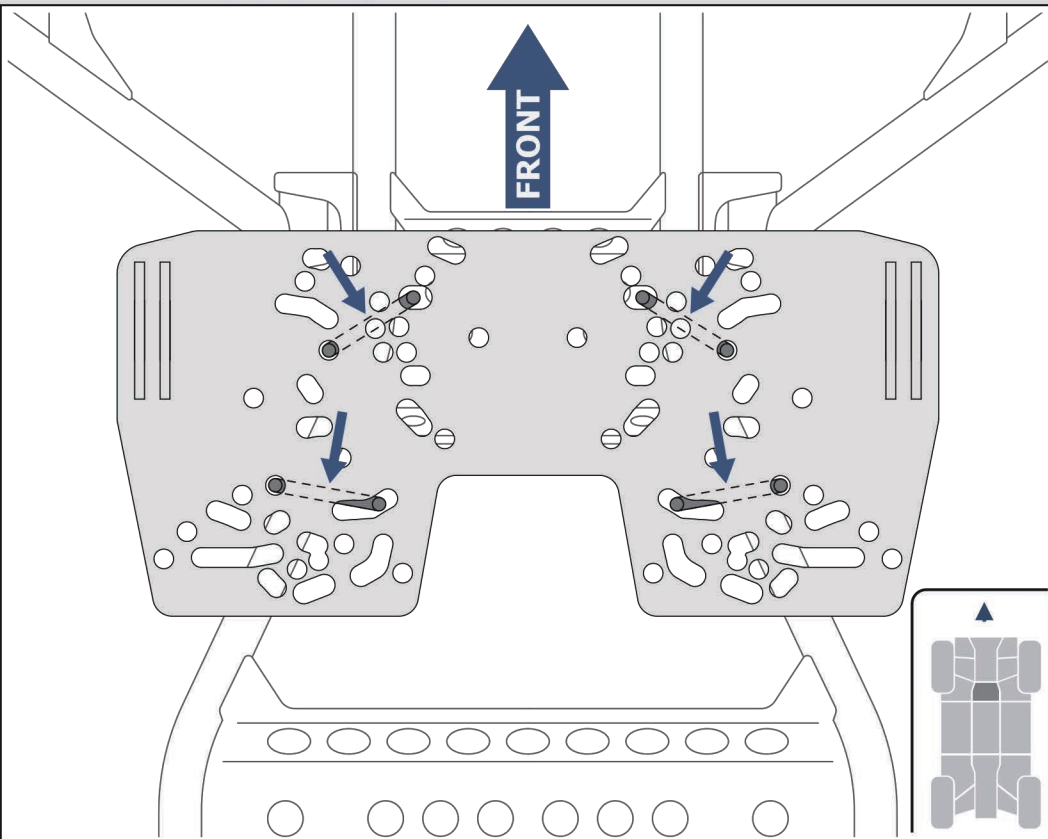
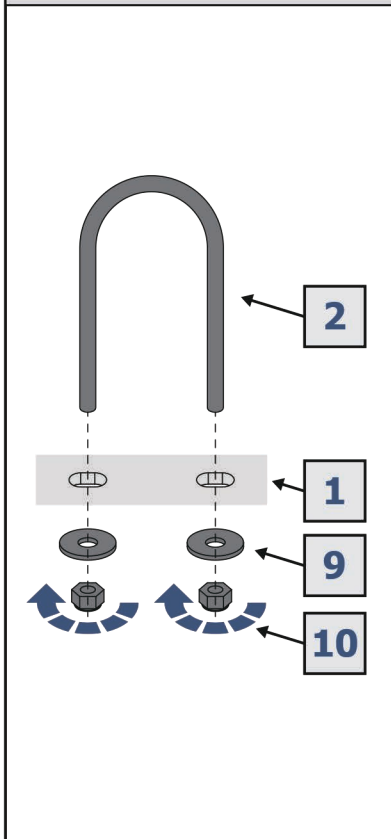

Yamaha: Kodiak 550, 700

